

ABC SECONDARY SCHOOL

Final Examination 200X Secondary 2 Express

Mathematics Paper 2 (50 marks)

Time: 8.00 - 9.30 am

October 200X

Duration : 1 hour 30 minutes

No Additional Materials Required

Name:

Sec. 2 / Reg. No.:

INSTRUCTIONS TO CANDIDATES

Write your name, class and register number in the spaces above.

Answer **all questions in Section A** and **one question in Section B**.

Write your answers in the spaces provided in the question paper.

If working is needed, it must be clearly shown below that question.

Omission of essential working will result in the loss of marks.

Silent electronic calculators may be used for this paper.

INFORMATION FOR CANDIDATES

The number of marks is given in brackets [] at the end of each question or part question.

You should not spend too much time on any one question.

This question paper consists of 7 printed pages.

Section A (40 marks) Answer all questions in this section.

- 1 (a) A baker uses 225g of flour in making a loaf of bread. How many kg of flour are required for 150 loaves?
- (b) 45% of the baker's total expenses are for cost of fuel and the remainder is for materials.
- (i) In the year 2007, the baker's total expenses were \$8 000. Calculate the cost of materials in 2007.
- (ii) In 2008, the cost of fuels increased by 10% and the cost of materials increased by 30%. Calculate the increase, in dollars, in the cost of the baker's materials and the percentage increase in his total expenses.

Ans: (a) [2]

(b) (i) [1]

(ii) [2]

-
- 2 The diagram shows a solid wax hemisphere of radius 6 cm. Calculate
- (i) the volume of the wax
- (ii) the total surface area of the hemisphere.
- (Take $\pi = 3.142$.)

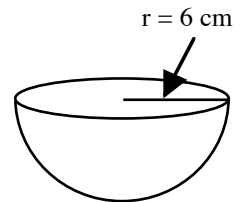

Ans: (i) [2]

(ii) [3]

- 3 (a) Given that 5 kg of tea and 2 kg of coffee cost \$81 and 1 kg of tea and 4 kg of coffee cost \$54, find the price of one kg of tea and one kg of coffee.

- (b) The diagram shows an equilateral triangle. Calculate its perimeter.
(Measurements are in cm.)

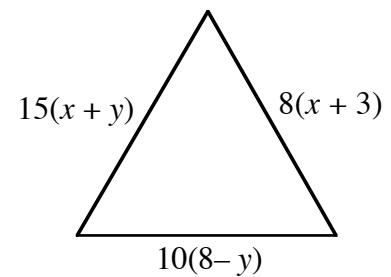

Ans: (a) Tea:, Coffee: [3]

(b) Perimeter of triangle = [3]

4 (a) Express as a single fraction $\frac{10}{10x+1} - \frac{4}{6x-9}$.

(b) Given that $y = \frac{a+3x}{2a}$, express x in terms of a and y .

(c) Solve $\frac{6x^2+13x+5}{4x^2-1} = 0$.

Ans: (a) [3]

(b) [2]

(c) [3]

- 5 In the space below, draw the image of triangle A under
 (a) a translation of 6 units in the x -direction and -6 units in the y -direction and label it T, [2]
 (b) an anti-clockwise rotation of 90° about the origin and label it R. [3]

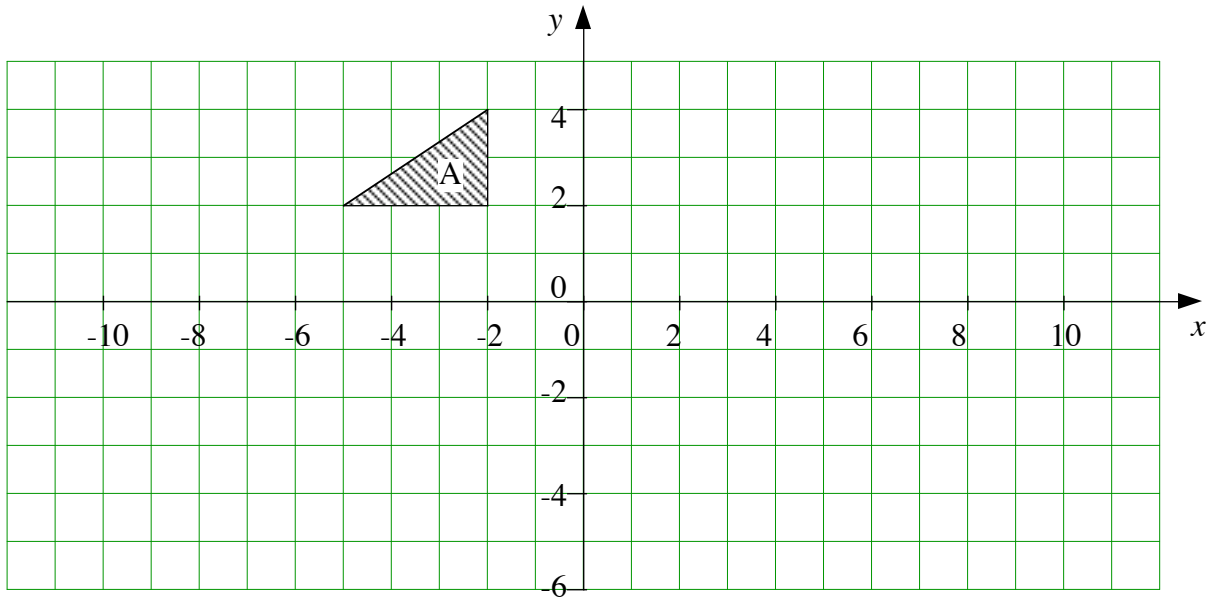

- 6 In the diagram, $\angle ACB = \angle AEC = \angle CAD = 90^\circ$. $AC = 3.9$ m, $CD = 4.4$ m and $\angle BAC = 58^\circ$.
 Calculate
 (a) the length of CE,
 (b) the length of AB,
 (c) the value of x .

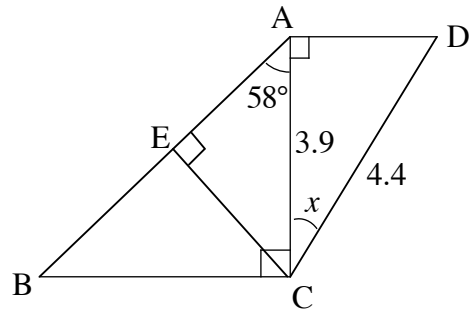

- Ans: (a) [2]
 (b) [2]
 (c) [3]

- 7 The histogram shows the number of goals scored by a team in 17 matches.
- Calculate the total number of goals scored.
 - Find the mode of the distribution.
 - Find the median of the distribution.
 - Calculate the mean of the distribution.

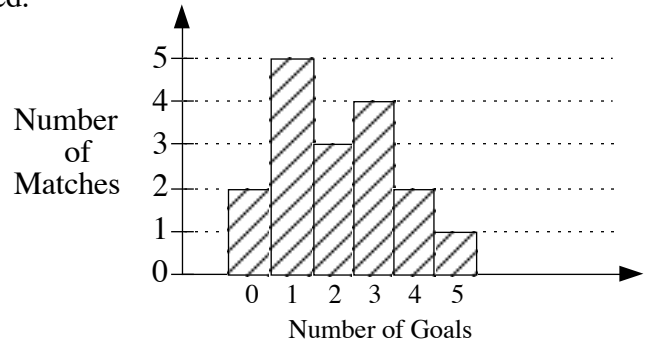

- Ans: (i) [1]
(ii) [1]
(iii) [1]
(iv) [1]

Section B (10 marks) Answer only **one** question in this section.

- 8 (a) The diagram shows a solid which consists of a cone of diameter 6 cm and height 4 cm joined to a cylinder. Calculate
- the value of ℓ ,
 - the area of the solid,
 - the volume of the solid. (Take π to be 3.142.)

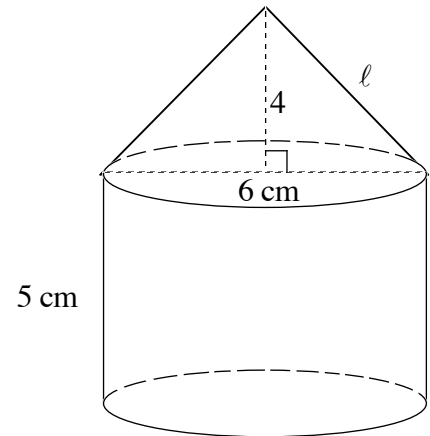

- Ans: (a) (i) [2]
(ii) [2]
(iii) [2]

- 8 (b) A solid sphere has a volume of 600 cm^3 . Taking π to be 3.142, calculate
 (i) its radius,
 (ii) its surface area.

Ans: (b) (i) [2]

(ii) [2]

- 9 In the diagram, $BE = 2 \text{ cm}$, $BC = 5 \text{ cm}$, $AE = 6 \text{ cm}$ and $\angle BDC = 35^\circ$. Calculate

- (a) AB ,
 (b) CD ,
 (c) ED ,
 (d) θ .

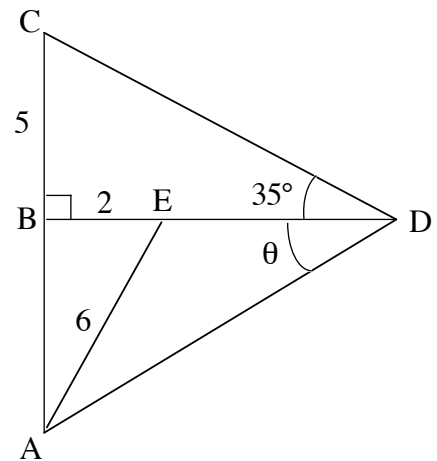

Ans: (a) [2]

(b) [3]

(c) [3]

(d) [2]